

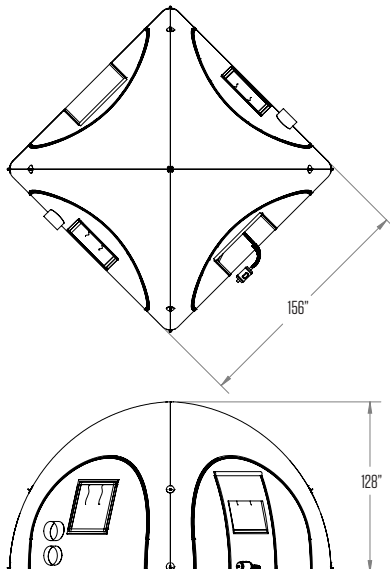

## SENTRY 13 AIRFRAME™ SHELTER

### Key Features and Benefits

- Rapidly deployable by only two people
- Lightweight design allows for a wide variety of transportation options
- Fits in a single package for easy storage
- Modular construction allows for simple connections to other shelters
- Sealable vinyl floor maintains environmentally secure shelter
- Optional zip-in connector joins shelters to form larger complexes
- Available in Beige (Part # SI-1313BG) and White (Part # SI-1313WT)



### Sentry 13 Specifications

Dimensions	13' x 13' x 10'6"	(3.9 x 3.9 x 3.2 m)
Weight	131 lbs	(59.5 kg)
Time Under Canopy	3 - 4 minutes	
Square Footage	162 ft <sup>2</sup>	(15 m <sup>2</sup> )
Cube	1180 ft <sup>3</sup>	(33.4 m <sup>3</sup> )
Tube Circumference	50"	(1.2 m)
Packaged Dimensions	48 x 36 x 20"	(1.2 x 0.9 x 0.5 m)
Vinyl Specs	Cover: 9 oz Vinyl	Floor: 18 oz Vinyl
Pump Dimensions	22 x 8 x 11"	(56 x 20 x 28 cm)
Pump Weight	26 lbs	(11.7 kg)
Pump Motor 8.0 Peak HP	19 Amps	2,280 Watts
Pump Airflow	58,500 FPM	