

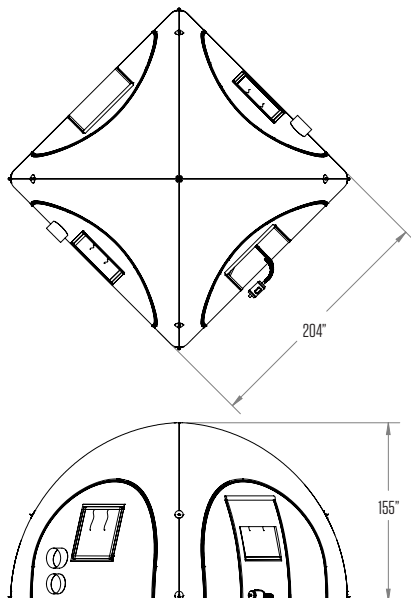

SENTRY 17 AIRFRAME™ SHELTER

Key Features and Benefits

- Rapidly deployable by only two people
- Lightweight design allows for a wide variety of transportation options
- Fits in a single package for easy storage
- Modular construction allows for simple connections to other shelters
- Sealable vinyl floor maintains environmentally secure shelter
- Optional zip-in connector joins shelters to form larger complexes
- Available in Beige (Part # SI-1717BG) and White (Part # SI-1717WT)



Sentry 17 Specifications

Dimensions	17' x 17' x 13'	(5.1 x 5.1 x 3.9m)
Weight	168 lbs	(76.2kg)
Time Under Canopy	3 - 5 minutes	
Square Footage	271 ft ²	(25.1m ²)
Cube	3733 ft ³	(105.7 m ³)
Tube Circumference	61"	(1.5m)
Packaged Dimensions	60 x 42 x 26"	(1.5 x 1 x 0.6m)
Vinyl Specs	Cover: 9 oz Vinyl	Floor: 18 oz Vinyl
Pump Dimensions	22 x 8 x 11"	(56 x 20 x 28 cm)
Pump Weight	26 lbs	(11.7 kg)
Pump Motor 8.0 Peak HP	19 Amps	2,280 Watts
Pump Airflow	58,500 FPM	