



RDS-100 OVERVIEW



RDS-100 FEATURES

- Under canopy with only 2 people in under 4 minutes
- Superior fabric and welded seams for full block out capabilities
- Withstands 55 mph winds
- RDS-100 must be staked and the use of guy lines is required - all come complete with each tent system
- Perfect for extremely short setup periods
- Western Shelter exclusive - this tent has no equal

RDS-100 END VIEW

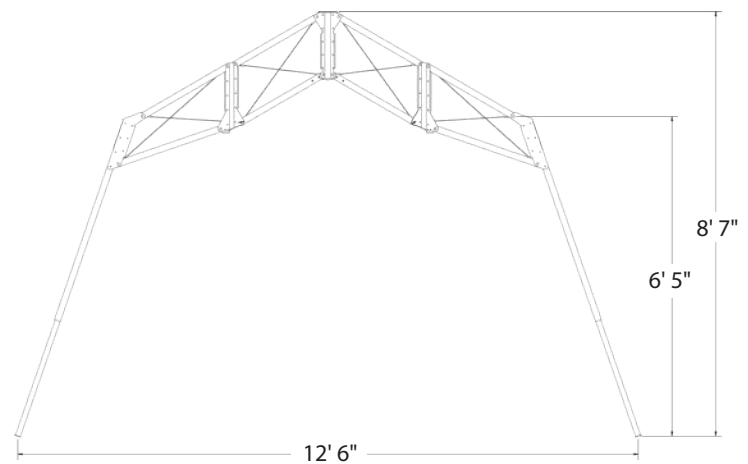

RDS-100 SPECIFICATIONS

Model Name:	RDS-100
Product Code / Green:	Product Code 2480529
Width:	12'6" 3.81m
Length:	8' 2.44m
Area:	100 sq. ft. 9.29m ²
Eave Height (interior):	6'5" 1.96m
Peak Height (without liner):	8'6" 2.59m
Minimum Site Area Required:	16' x 20'6" 4.88m x 6.25m
Pack #1 Size (frame):	55" x 17" x 12" 1.40m x 0.432m x 0.305m
Pack #2 Size (fabric & stakes):	55" x 14" diameter 1.40m x 0.356m diameter
Weight Pack #1 (frame):	70 lbs. 31.75kg
Weight Pack #2 (fabric & stakes):	61 lbs. 27.67kg
Total System Weight:	131 lbs. 59.42kg
ECU Ducts:	0
Windows:	6
Stove Pipe Vents:	0
Doors:	2
Personnel Required:	2
Set-up Time:	< 4 minutes
Snow Load:	N/A
Wind/Rain:	Sustained winds of 55 mph (88.513km/h) 2" (50.8mm) per hour
Durability:	Exceeded requirement of 50 set and strikes
Thermal Liner:	N/A
# of Lights:	2 (BATLite™ LED lights)
ECU Size:	N/A
Flooring:	N/A

